

















Mercury360

www.antec.com

Accessories			
 A: Intel Buttons X1	 B: AMD/AM4 Buttons X1	 C: Back plate X1	 D: AM4 Back plate X1
 E: Knurled nuts (M3*18) X4	 F: Screw (H7*36*M3) X4	 G: Knurled nuts (M3*12) X4	 H: 2011/2066 of the screw X4
 I: Screw (6-32*6) X16	 J: Gasket (4*10*1) X4	 K: Grews(6-32*30) X16	 L: Fan X3
 M: Buckle screw (M3*9) X4	 N: KB5X10 fan self-tapping X16	 O: Fan gasket X16	 P: The power cord X 1

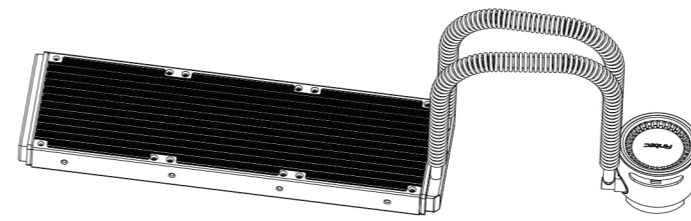

Intel Installed

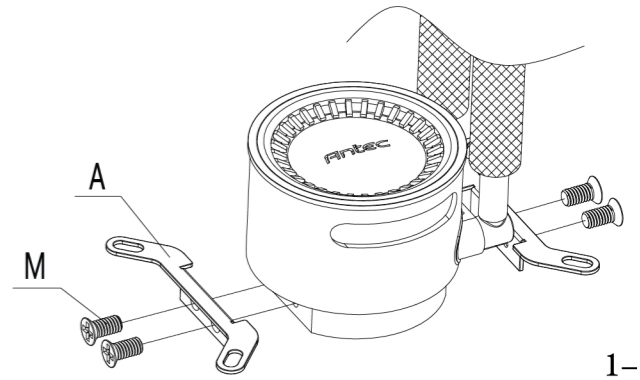

1-1

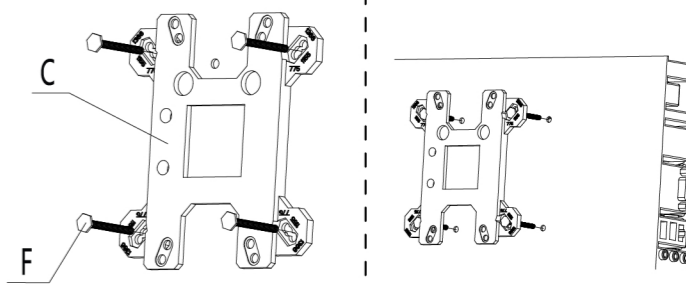

1-2

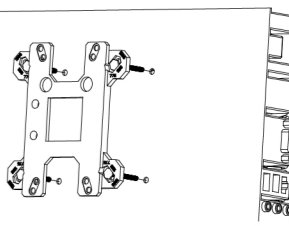

1-3

2011/2066 of the installation

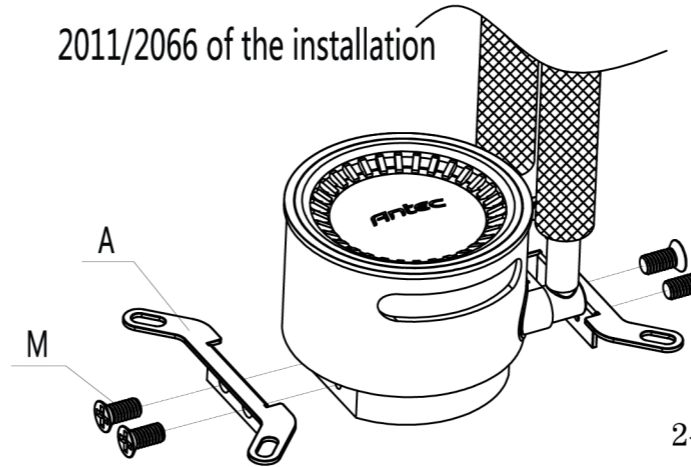

2-1

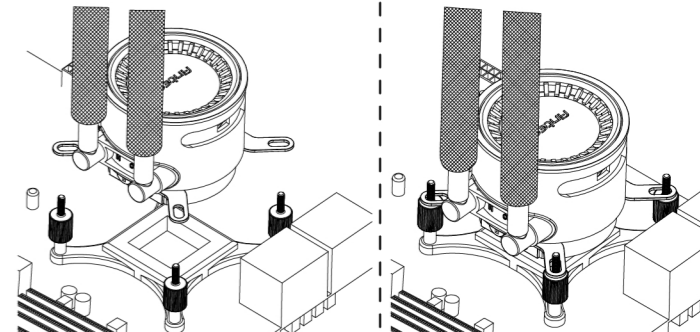

2-4

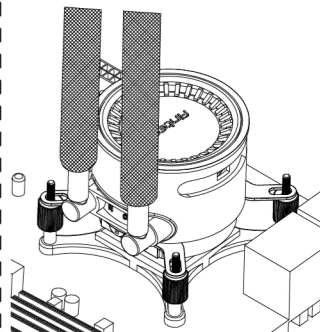

2-5

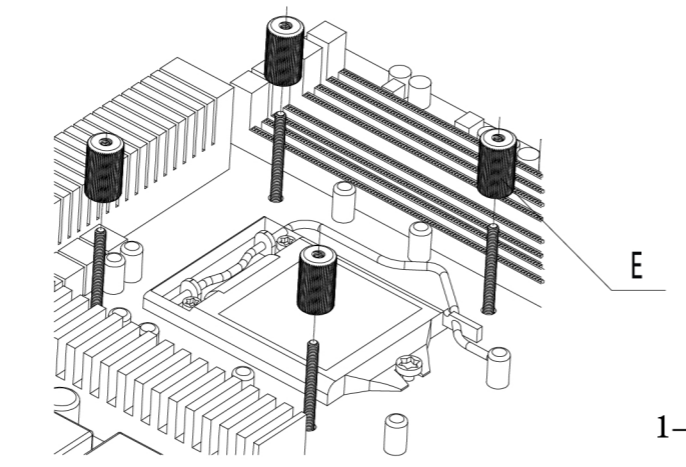

1-4

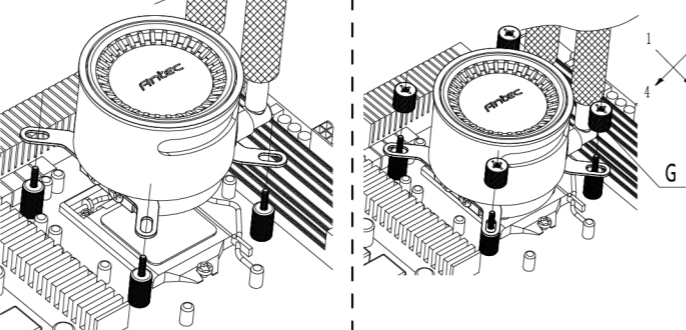

1-5



1-6

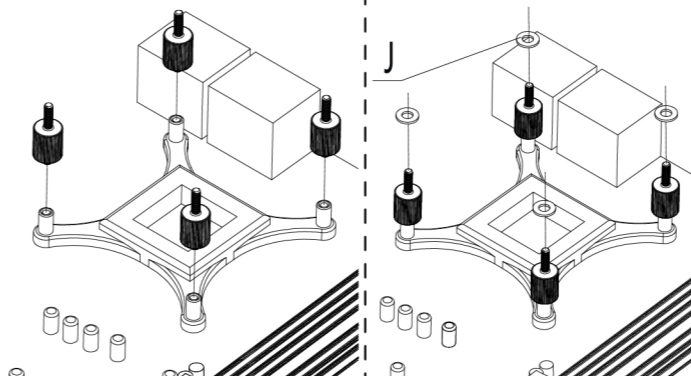

2-2

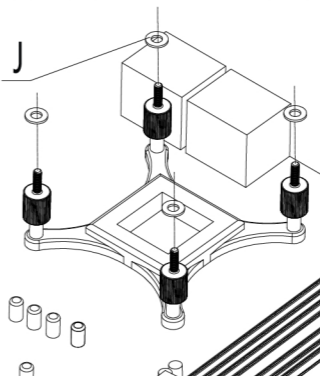

2-3

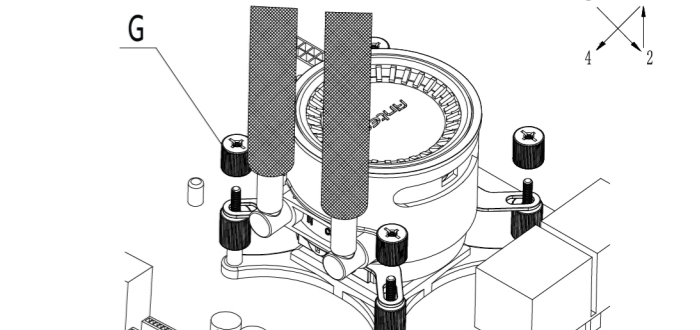

2-6

ANTEC QUALITY 5-YEAR WARRANTY

For details on the Antec warranty period of your product, Antec warranty terms, product returns and repair procedure, Antec Customer Support services and contact information, please visit or contact:

Online: www.antec.com/support

US & Canada: 1-800-22ANTEC (standard international call charges may apply) nausupport@antec.com

Europe & Africa: +31-(0)10-4822060 (standard international call charges may apply) euasupport@antec.com

Asia & Pacific: +886-(0)800-060-696 (standard international call charges may apply) apausupport@antec.com

PLEASE KEEP YOUR PURCHASE RECEIPT.

Antec, Inc. warrants its new products to be free from defects resulting from faulty manufacture or faulty components under the following terms and conditions:

I. **Warranty Length.** For new Antec products, parts and labor are warranted for five (5) years from the date of purchase. Replacement products will be warranted for the remainder of the warranty period or thirty days, whichever is longer.

II. **Who is Protected.** This warranty is enforceable only by the original consumer purchaser. Proof of purchase is required for warranty service.

III. **What is And is Not Covered.** Note that our warranty is not an unconditional guarantee for the 5-year length of the warranty. Antec products are made under our exacting manufacturing standards. But, like any other product, they are not indestructible. Therefore, our warranty does not cover product damage that results from abuse or misapplication of the products, nor does it cover incidental or consequential damage. The following are not covered by the warranty: 1) Any product which has been modified without permission from Antec, or on which the serial number or warranty sticker has been defaced, modified, or removed; 2) Normal wear and tear; 3) Damage, deterioration or malfunction resulting from: Accident, abuse, misuse, neglect, fire, water, lightning, or other acts of nature, unauthorized product modification or failure to follow instructions included with the product; repair or attempted repair not authorized by Antec, Inc.; shipping or transport damage; claims must be made with the carrier; any other cause which does not relate to a product defect; 4) Carcass, cases, batteries, cabinets, tops, accessories or other consumables used with this product; 5) Antec, Inc. does not warrant that this product will meet your requirements. It is your responsibility to determine the suitability of this product for your purpose; 6) Removal or installation charges; 7) Shipping charges; 8) Any incidental charges.

IV. **Exclusion Of Damages.** Antec's sole obligation and liability under this warranty is limited to the repair or replacement of a defective product at our option. Antec shall not, in any event, be liable for any incidental or consequential damage, including but not limited to damages resulting from interruption of service and loss of business, or for liability in tort relating to this product or resulting from its use or possession.

For Australia only: Our goods come with guarantees that cannot be excluded under the Australian Consumer Law. You are entitled to a replacement or refund for a major failure and for compensation for any other reasonably foreseeable loss or damage. You are also entitled to have the goods repaired or replaced if the goods fail to be of acceptable quality and the failure does not amount to a major failure. (Antec, Inc., 48017 FREMONT BLVD., FREMONT, CA 94538, USA, Tel: 910-770-1200 (standard international call charges may apply))

V. **Limitations Of Implied Warranties.** There are no other warranties, expressed or implied, including but not limited to those of merchantability or fitness for a particular purpose. The duration of implied warranties is limited to the warranty length specified in Paragraph I.

VI. **Local Law And Your Warranty.** This warranty gives you specific legal rights. You may also have other rights granted under local law. These rights may vary.

VII. **To Obtain Technical Support.** Please see your product owner's manual or visit www.antec.com for details and contact information.

VIII. **For Warranty Service.** In the event that warranty repair or replacement is required, Antec will request and you must provide proof of purchase (store receipt or invoice) in order to receive warranty service.

Outside North America or Europe: If your product needs to be returned within the warranty period, please do so through the retailer or distributor from whom you purchased the product. Antec will not accept returns without prior approval and an RMA number.

In North America: Within the first 30 days after purchase, please return your product to the dealer from whom you purchased it for a replacement. If the product is still within warranty and you can no longer return it to your dealer, please contact Antec Customer Support (see above) for assistance and instructions. Antec will not accept returns without prior approval and an RMA number.

In Europe: Within the first year after purchase, please return your product for power supplies installed within our enclosures, just the failed power supply to your dealer or retailer for a replacement. If the product is still within warranty and you can no longer return it to your dealer, please contact Antec Customer Support (see above) for assistance and instructions. Antec will not accept returns without prior approval and an RMA number.

When returning product, please be sure to enclose a clear description of the problem and your proof of purchase with the defective product and return it as instructed by the product security guidelines in its return shipping and ship it outside. Your dealer or Antec will not be responsible for damage due to shipping. During the warranty period, your product will be repaired or replaced without charge, excluding shipping and handling.

AMD installed

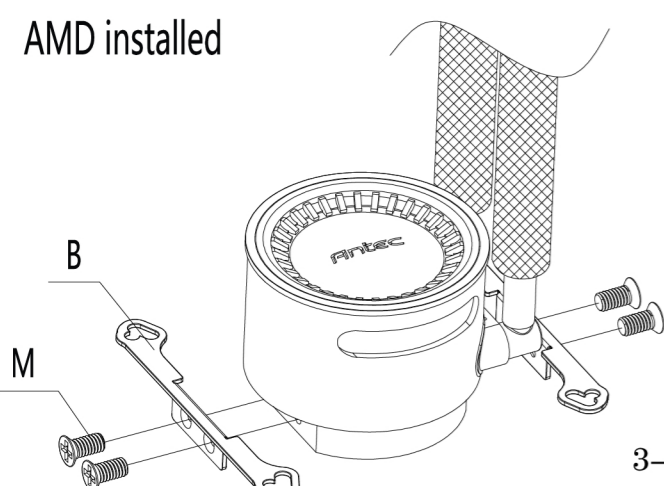

3-1

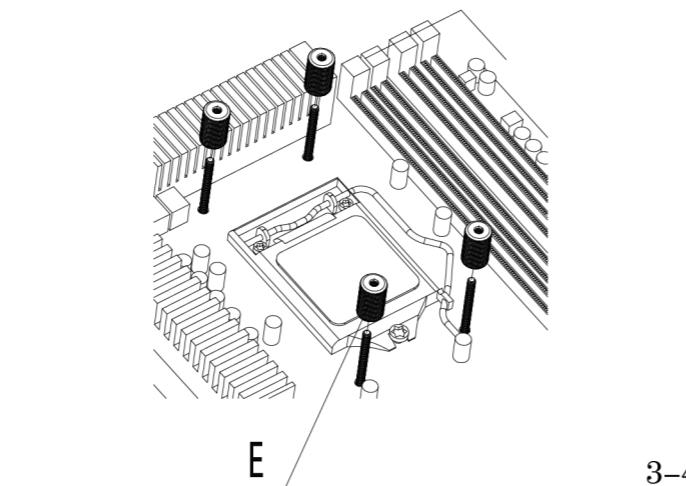

3-4

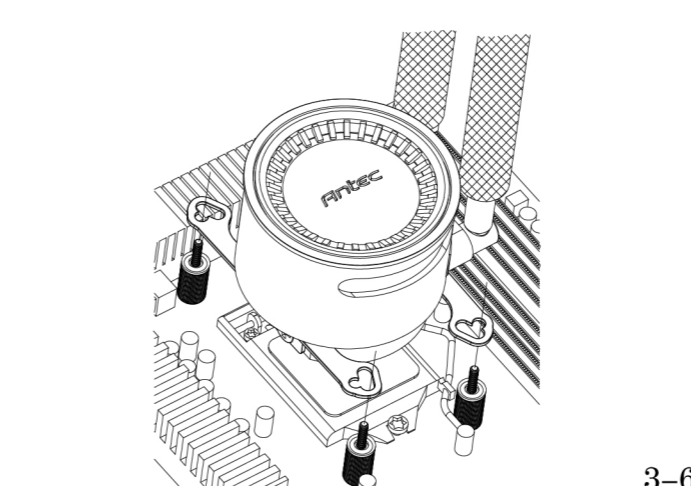

3-6

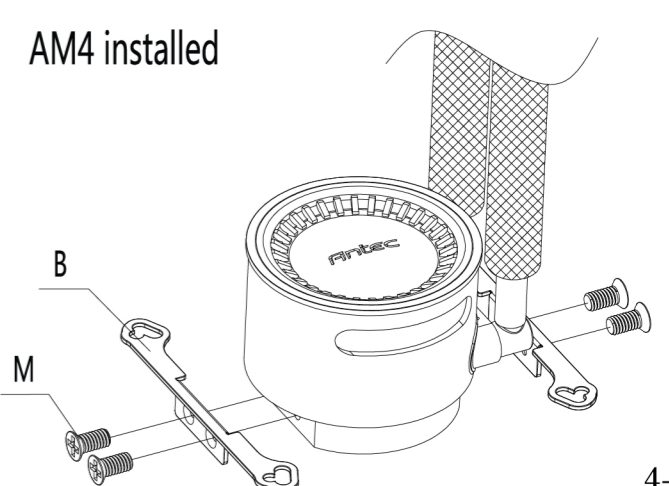

4-1

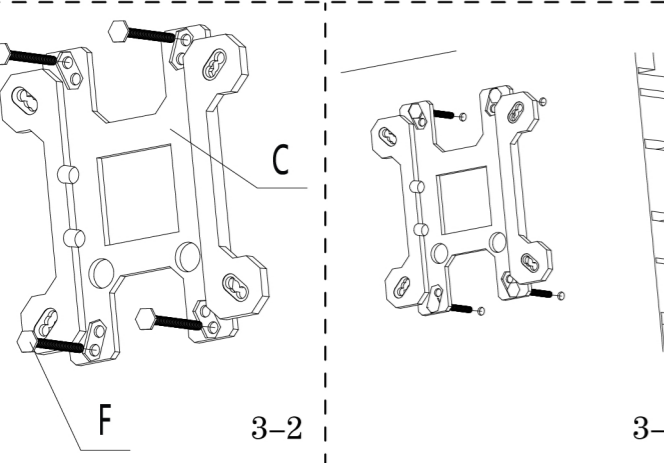

3-2



3-3

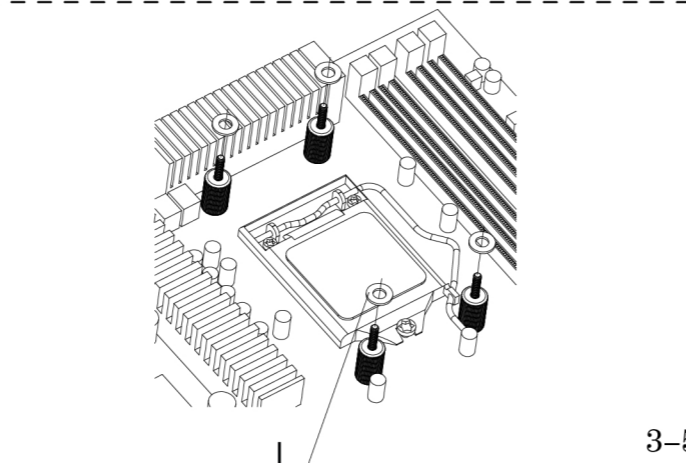

3-5

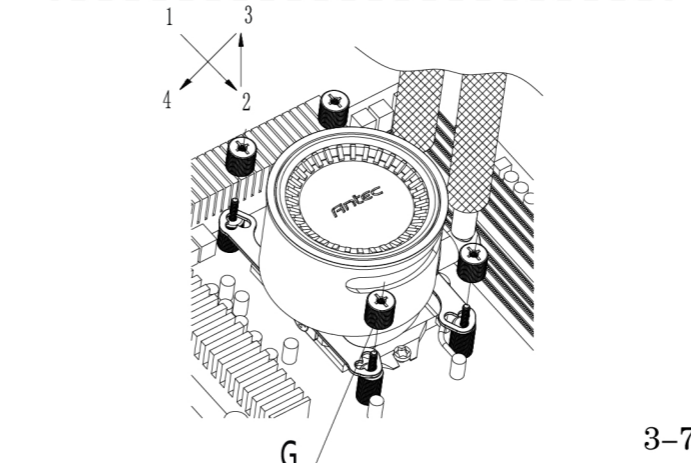

3-7

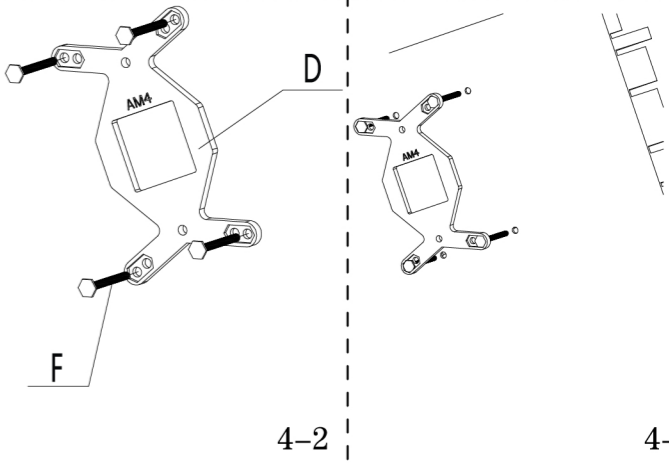

4-2

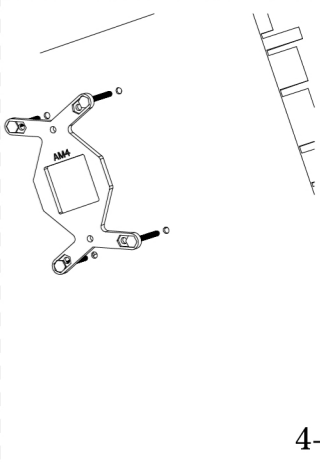

4-3

Fan installed-1

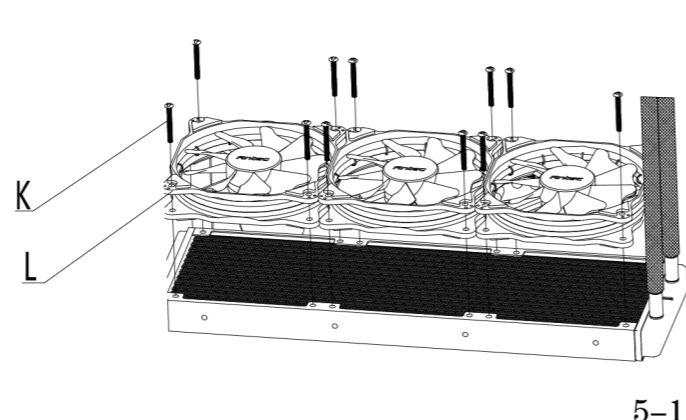

5-1

Fan installed-2

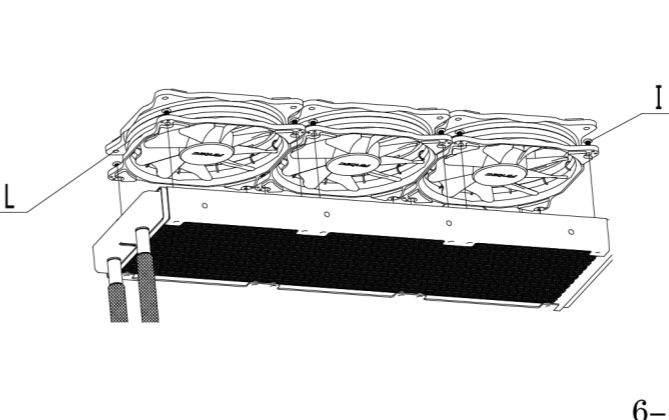

6-1

Fan power installation

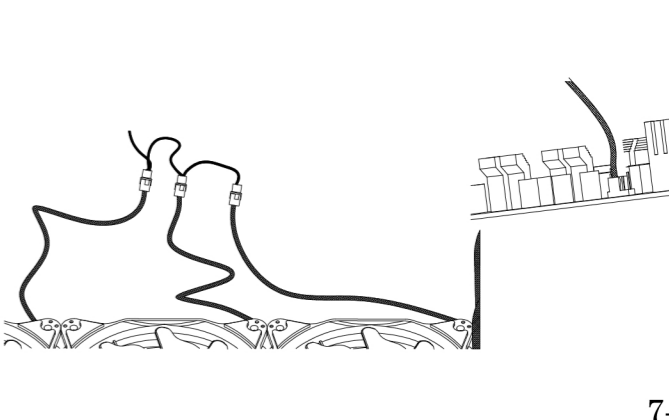

7-1

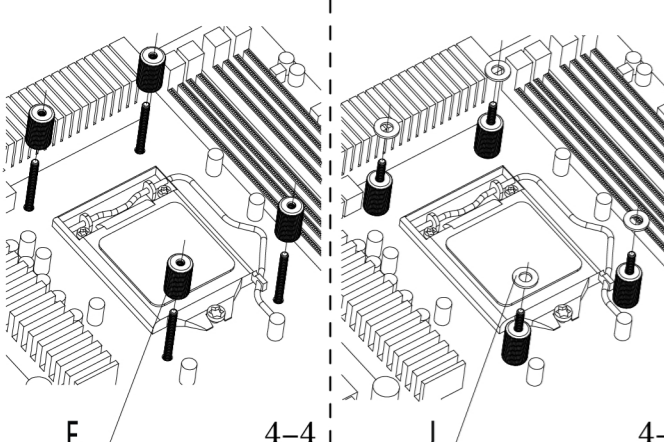

4-4

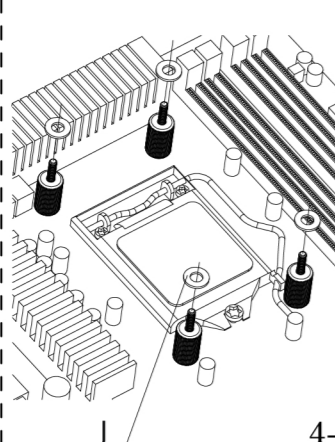

4-5

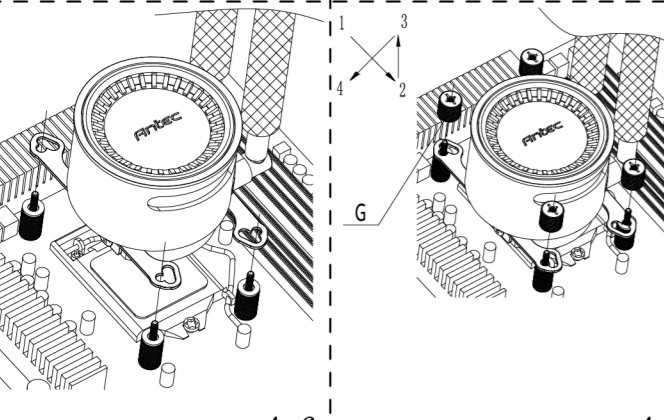

4-6



4-7

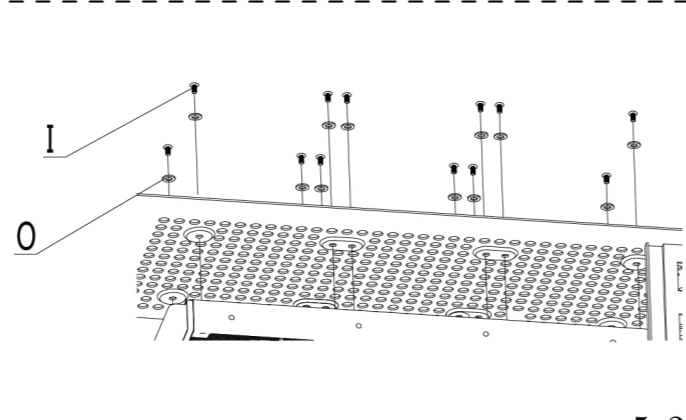

5-2

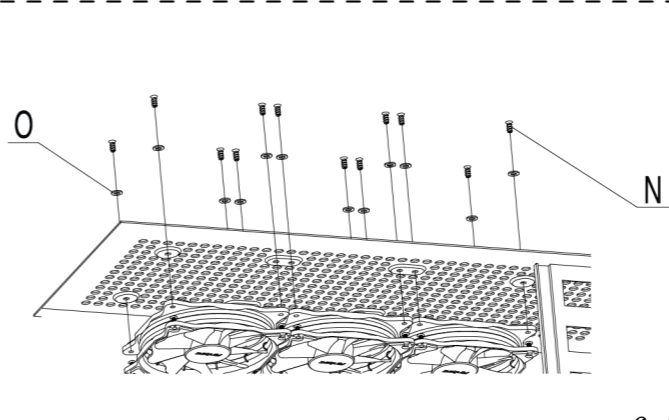

6-2

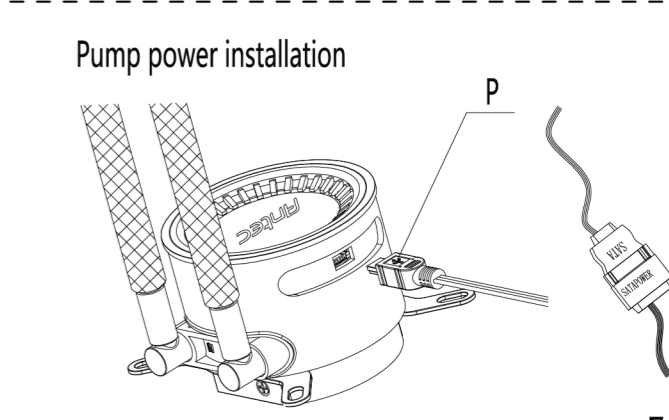

7-2

Pump power installation

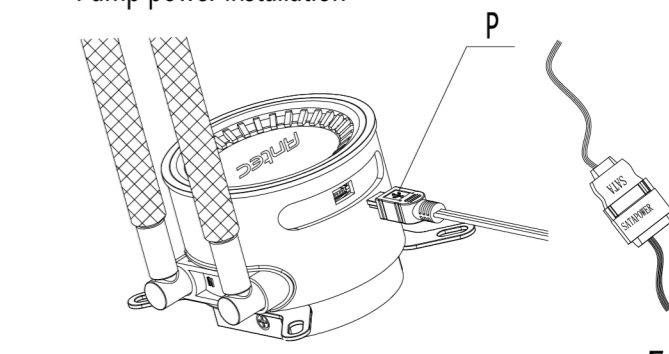

7-2